



Ravaglioli

COMPANY
WITH QUALITY SYSTEM
CERTIFIED BY DNV
= ISO 9001/2000 =

SMONTAGOMME AUTOMATICI SENZA LEVA

AUTOMATIC TYRE CHANGERS WITHOUT MOUNTING LEVER

AUTOMATISCHE REIFENMONTIERGERÄTE OHNE MONTIERHEBEL

G

1200.34
slim

COMPLETAMENTE SENZA LEVA
COMPLETELY LEVERLESS
KOMPLETT HEBELLOS



1958 | 2008

EXCLUSIVE
AUTO-TOUCH FUNCTION



AUTO-TOUCH function



**PATENTED
BREVETTATO**



L'utensile si inserisce fra tallone e cerchio.

The tool inserted between heel and rim.

Die Montagevorrichtung dringt zwischen Wulst und Felge ein.



Facendo leva sul cerchio, l'utensile solleva il tallone con il minimo stress.

Levering on the rim, the tool pulls up the bead, minimising the stress.

Diese drückt gegen die Felge und hebt somit mit min. Stress den Wulst hoch.



Il tallone viene sollevato progressivamente.

The bead is progressively pulled up.

Der Wulst wird schrittweise hochgehoben.

AUTO-TOUCH

Può operare su:	Can operate on:	Arbeitet mit:
- cerchi normali o rovesci	- both normal and reverse rims	- Normalen oder umgekehrten Felgen
- Run Flat	- Run Flat	- Run Flat
- SST	- SST	- SST
- BSR	- BSR	- BSR
- PAX	- PAX	- PAX

- Diametro ruota fino a 50" (configurabile anche fino a 52"/154")
- Diametro cerchio da 10" a 30" (configurabile anche fino a diametro da 14" a 34")
- Larghezza cerchio max 15"

- Wheel diameter up to 50" (it may be set up to 52"/154")
- Rim diameter from 10" to 30" (it may be set with diameter up to 14" to 34")
- Rim width up to 15"

- Raddurchmesser bis zu 50" (einstellbar bis zu 52"/154")
- Felgendurchmesser von 10" bis 30" (einstellbar von 14" bis 34")
- Felgenbreite bis max 15"

SELF-LOCKING PLATE

**PATENTED
BREVETTATO**



Il bloccaggio centrale, idoneo anche per ruote rovesce, avviene tramite un perno centrale con cono. Lo sforzo è minimo grazie allo speciale **piattello di appoggio ruota, di tipo flottante con effetto auto-bloccante.**

The central rim locking system, suitable also for reverse rims, consists of a central pin with cone. The effort is minimal thanks to the special plate on which the wheel lays. The plate is floating, therefore offering a self-locking mechanism.

Die Zentrale Spannvorrichtung, die aus einem Zentrierbolzen und Konus besteht, ist auch für umgekehrte Felgen geeignet.
Das Radspannen erfolgt dank einer selbstarretierenden Radscheibe schnell und mit min. Kraftaufwand.

WHEEL SENSOR

**PATENTED
BREVETTATO**



Lo stallonamento viene fatto tramite due rulli con controllo elettronico:

- un **sensore attiva automaticamente lo stallonamento**, che agisce in posizione corretta e non sul fianco del pneumatico
- lato superiore e inferiore vengono stallonati da due rulli opposti in rapida successione.

The bead-breaking is performed by means of two electronically controlled rollers:

- a **sensor automatically activated the bead breaker**, which operates in the correct position and not on the rim side
- bead-breaking of both sides is quickly performed

Der Reifen wird mittels zwei, elektronisch gesteuerten Abdrückrollen vollzogen:

- **Ein Sensor steuert automatisch den Abdrückvorgang** indem er die Rollen immer an der richtigen Stelle abdrücken lässt.
- Der untere und obere Wulst werden sukzessiv von zwei gegenüberliegenden Rollen schnell und sicher abgedrückt.

G 1200.34 IT *slim*

Versione con gonfiatubeless brevettato TOP

Gonfiaggio potente e sicuro:

- una mano tiene l'ugello di gonfiaggio, l'altra resta libera
- il getto è verso il basso, a totale sicurezza
- la spinta all'indietro è ridotta, grazie al sistema brevettato
- un dispositivo di sicurezza impedisce l'uso accidentale contro altre persone o cose

Version with patented TOP inflation device

Powerful and safe inflation:

- one hand operation
- downward inflation flow, granting utmost safety
- the draw back effect is reduced, thanks to patented system
- a special safety device prevents accidental use against other people or objects

Version mit patentierter TOP-Reifenfüllvorrichtung

Kräftige und sichere Reifenbefüllung:

- Eine Hand hält die Reifenbefülldüse während die andere frei bleibt
- Der Luftausstoß geht nach unten, in tot. Sicherheit
- Der Gegendruck ist dank eines Patentes auf das Minimum reduziert.
- Eine Sicherheitsvorrichtung verhindert den ungewollten Einsatz auf Personen oder Gegenstände

Eccellenza prodotto Made in Italy

Tutti i prodotti all'interno di questo catalogo sono progettati, sviluppati e costruiti in Italia.

Top product - Made in Italy

All products shown in this leaflet are designed, developed and manufactured in Italy

Italienisches Spitzenprodukt

Alle Produkte in diesem Prospekt werden in Italien entwickelt und gebaut



STANDARD

- Gonfiaggio rapido a pedale con manometro e valvola bilanciatrice
- Protezione piattello appoggio ruota
- Premitalone 28" con trazione (G1000A67)
- Quick pedal operated inflation with gauge and balancing valve
- Protection for central locking plate
- 28" bead-pushing device with pulling system (G1000A67)
- Pedalgesteuerte Reifenfüllvorrichtung mit Manometer und Druckventil
- Radscheibeschutzvorrichtung
- 28" Wulstketten mit Zugvorrichtung (G1000A67)

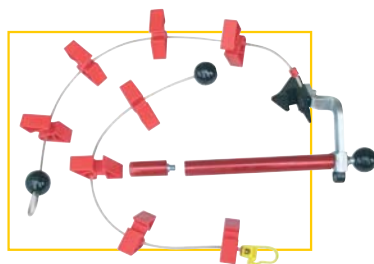

INVE MOTOR

Il motore opera tramite un inverter esclusivo di ultima generazione che:

- permette di **regolare a piacere la velocità di rotazione** tramite il pedale
- rallenta automaticamente la rotazione con l'aumentare dello stress sul tallone (per evitare danni al pneumatico)

The electrical motor is equipped with an exclusive and innovative inverter, which:

- allows to **regulate the chucking table rotation speed** by pressing the pedal
- slows down the rotation speed as the stress on the bead increases (to avoid any damage to the tyre)

Der Motor arbeitet mit einem speziellem Schalter letzter Generation:

- Dieser ermöglicht durch einfachen Pedaldruck die **Drehgeschwindigkeit zu steuern**
- Verlangsamt automatisch die Drehung bei ansteigendem Stress auf dem Wulst. (um Reifenschäden zu vermeiden)

OPTIONS



G1000A60K (20 x kit)

Protezione ruote rovesce in plastica
Set of plastic protections for support plate
Satz Scheiben-Schutz (Kunststoff)



G1000A81K (10 x kit)

Protezione ruote rovesce in gomma
Set of rubber protections for support plate
Satz Scheiben-Schutz (Gummi)

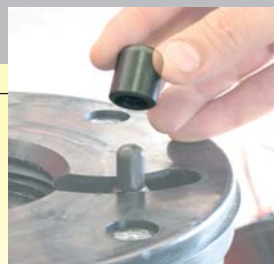

G1000A70K (5 x kit)

Protezione trascinatore
Set of protections for pulling unit
Satz Schutz Zugvorrichtung



PLUS91 AKL

Dispositivo premitallone rotante pneumatico
Rotating arm with pneumatic bead pushing device
Drehender pneumatischer Wulstniederhalter



G1000A82

Sollevatore pneumatico ruote.
Pneumatic wheel lifter.
Pneumatischer Radheber.



G1000A66K (5 x kit)

Protezione cono di bloccaggio
Set of protections of locking cone
Satz Schutz Zugvorrichtung

G 1200.34 slim

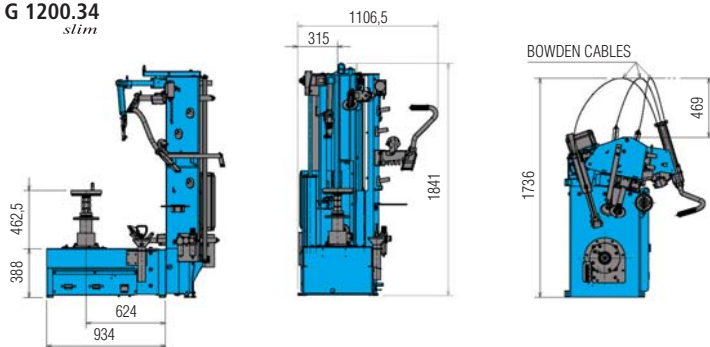

G1000A72

Flangia universale per ruote senza foro centrale e adatta anche a ruote rovesce
Universal flange for closed centre, adapted also for reverse rims.
Universalfansch für Räder mit Blindbohrungen, geeignet auch für Reverse-Rim-Design.

DATI TECNICI	TECHNICAL DATA	TECHNISCHE DATEN	
Lavora su ruote da	Handled wheels from	Geeignet für Räder	34"
Peso	Weight	Gewicht	370 kg
Larghezza max ruota	Max wheel width	Radbreite, max.	15"
Diam. max ruota (mm)	Max wheel diam. (mm)	Raddiameter, max (mm)	1370 (54")
Forza di stallon.(ogni rullo)	Bead break.pow.(each arm)	Abdrückkraft (jeder Arm)	1200 kg
Coppia max	Max torque	Drehmoment, max	120 Kgm
Movimento di stallonam.	Bead breaker movement	Abdrückbewegung	automatic
Motore di rotazione	Rotation Motor	Motor Drehung	1,5 Kw in motor +0,75 Kw motor
Pressione raccomandata	Recommended air supply	Empfohlener Druck	8 -10 bar
Voltaggio	Power Supply	Voltage	1ph, 200/265v, 50/60Hz



Ravaglioli S.p.A.

40037 Sasso Marconi
Fraz. Pontecchio M.
P.O.B. 1690 - Bologna - Italia
Tel. +39 - 051 - 6781511
Tel. +39 - 051 - 846349
rav@ravaglioli.com
www.ravaglioli.com

RAV France

6, Rue Longue Raie
ZAC de la Tremblaie
91220 Le Plessis Pâte
Tel. 01.60.86.88.16
Fax 01.60.86.82.04
rav@ravfrance.fr

Ravaglioli Deutschland

Kirchenpoint 22
85354 Freising
Tel. 08165-646956
Fax 08165-646958
info@ravaglioli.de

RAV Equipment UK LTD

Prince Albert House
20 King Street
Maidenhead, SL6 1DT
Tel. 020-76286832
Fax 020-76286833
ravuk@ravaglioli.com

RAV en Belgique

Nederlandstalig
Tel. 0498-162016
Fax 016-781025
Zone Francophone
Tel. 0498-163016
Fax +32 78 055 030

RAV Equipos España

Avenida Europa 17
Pol. Ind. de Constanti
Tarragona 43120
Tel. 977 524525
Fax 977 524532
ravequipos@ravaglioli.e.telefonica.net