



Ravaglioli

COMPANY WITH QUALITY MANAGEMENT
SYSTEM CERTIFIED BY DNV
= ISO 9001:2008 =

SMONTAGOMME AUTOMATICI SENZA LEVA

AUTOMATIC TYRE CHANGERS WITHOUT MOUNTING LEVER

AUTOMATISCHE REIFENMONTIERGERÄTE OHNE MONTIERHEBEL

G

1160.30
swift

COMPLETAMENTE SENZA LEVA
COMPLETELY LEVERLESS
KOMPLETT HEBELLOS

SWIFT



EXCLUSIVE

AUTO-TOUCH FUNCTION



SINCE 1958





AUTO-TOUCH function

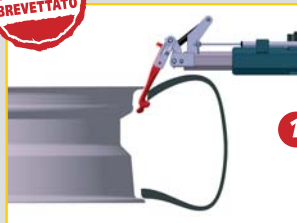

1

L'utensile si inserisce fra tallone e cerchio.

The tool operated between bead and rim.

Die Montagevorrichtung dringt zwischen Wulst und Felge ein.



2

Facendo leva sul cerchio, l'utensile solleva il tallone con il minimo stress.

Levering on the rim, the tool pulls up the bead, minimising the stress.

Diese drückt gegen die Felge und hebt somit mit min. Stress den Wulst hoch.

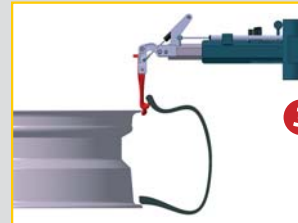

3

Il tallone viene sollevato progressivamente.

The bead is progressively pulled up.

Der Wulst wird schrittweise hochgehoben.



AUTO-TOUCH

Può operare su: - cerchi normali o rovesci - Run Flat - SST - BSR	Can operate on: - both normal and reverse rims - Run Flat - SST - BSR	Arbeitet mit: - Normalen oder umgekehrten Felgen - Run Flat - SST - BSR
---	---	---

- Diametro ruota fino a 45"
- Diametro cerchio da 10" a 30"
- Larghezza cerchio max 15"
- Wheel diameter up to 45"
- Rim diameter from 10" to 30"
- Rim width up to 15"
- Raddurchmesser bis zu 45"
- Felgendurchmesser
- Felgenbreite bis max 15"

SYNCRO ROLLERS

Lo stallonamento viene fatto tramite due rulli con movimento sincronizzato. Lato superiore e inferiore vengono stallonati da due rulli opposti in rapida successione.

The bead-breaking is performed by means of two rollers with a synchronized movement. The bead-breaking of both sides is quickly performed

Der Reifen wird mittels zwei Abdrückrollen vollzogen mit Synchronlauf. Die untere und obere Wulst werden sukzessiv von zwei gegenüberliegenden Rollen schnell und sicher abgedrückt.

ADJUSTABLE LOCKING

Base estendibile a 3 posizioni con configurazione standard 10"-26". L'operatore può ampliare il campo di lavoro fino a 30".

3-position extendable base with standard configuration 10"-26". The operator can extend the working range of the locking table up to 30".

Auf 3 Positionen erweiterbare Basis mit Standard-Konfiguration 10"-26". Der bediener kann den Arbeitsbereich bis 30" erweitern.

- 10"-26"
- 12"-28"
- 14"-30"

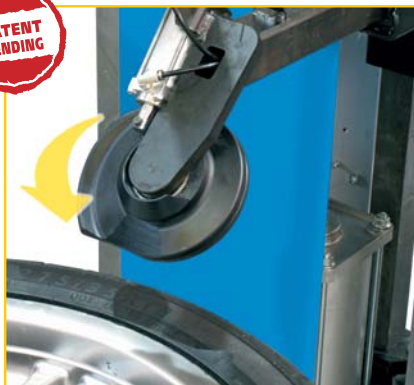



0-15 INVE MOTOR RPM VARIABLE SPEED

Standard

Il motore opera tramite un inverter esclusivo di ultima generazione che:

- permette di **regolare a piacere la velocità di rotazione** tramite il pedale
- **rallenta automaticamente** la rotazione con l'aumentare dello stress sul tallone (per evitare danni al pneumatico)

The electrical motor is equipped with an exclusive and innovative inverter, which:

- allows to **regulate the chucking table rotation speed** by pressing the pedal
- **slows down the rotation speed** as the stress on the bead increases (to avoid any damage to the tyre)

Der Motor arbeitet mit einem speziellem Schalter letzter Generation:

- Dieser ermöglicht durch einfachen Pedaldruck die **Drehgeschwindigkeit zu steuern**
- Verlangsamt automatisch die Drehung bei ansteigendem Stress auf dem Wulst. (um Reifenschäden zu vermeiden)

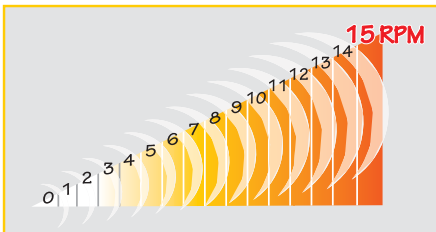

SELF-LOCKING PLATE

Il bloccaggio centrale, idoneo anche per ruote rovesce, avviene tramite un perno centrale con cono. Lo sforzo è minimo grazie allo speciale **piattello di appoggio ruota, di tipo flottante con effetto auto-bloccante.**

*The central rim locking system, suitable also for reverse rims, consists of a central pin with cone. The effort is minimal thanks to the special plate on which the wheel lays. **The plate is floating, therefore offering a self-locking mechanism.***

Die Zentrale Spannvorrichtung, die aus einem Zentrierbolzen und Konus besteht, ist auch für umgekehrte Felgen geeignet.

Das Radspannen erfolgt dank einer selbstarretierender Radscheibe schnell und mit min. Kraftaufwand.

G1160.30 SWIFT IT

Versione con gonfiatubeless brevettato TOP

Gonfiaggio potente e sicuro:

- una mano tiene l'ugello di gonfiaggio, l'altra resta libera
- il getto è verso il basso, a totale sicurezza
- la spinta all'indietro è ridotta, grazie al sistema brevettato
- un dispositivo di sicurezza impedisce l'uso accidentale contro altre persone o cose

Version with patented TOP inflation device

Powerful and safe inflation:

- one hand operation
- downward inflation flow, granting utmost safety
- the draw back effect is reduced, thanks to patented system
- a special safety device prevents accidental use against other people or objects

Version mit patentierter TOP-Reifenfüllvorrichtung

Kräftige und sichere Reifenbefüllung:

- Eine Hand hält die Reifenbefülldüse während die andere frei bleibt
- Der Luftausstoß geht nach unten, in tot. Sicherheit
- Der Gegendruck ist dank eines Patentes auf das Minimum reduziert.
- Eine Sicherheitsvorrichtung verhindert den ungewollten Einsatz auf Personen oder Gegenstände

STANDARD

- Gonfiaggio rapido a pedale con manometro e valvola bilanciatrice
- Protezione piattello appoggio ruota
- Premitalлоне 28" con trazione (G1000A67)
- Dispositivo di bloccaggio ruota
- Quick pedal operated inflation with gauge and balancing valve
- Protection for central locking plate
- 28" bead-pushing device with pulling system (G1000A67)
- Wheel blocking device
- Pedalgesteuerte Reifenfüllvorrichtung mit Manometer und Druckventil
- Radscheibenschutzvorrichtung
- 28" Wulstketten mit Zugvorrichtung (G1000A67)
- Radspannvorrichtung

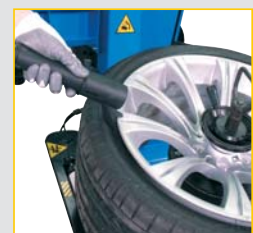
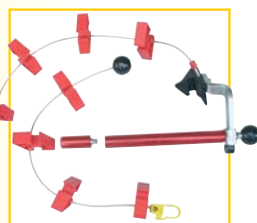

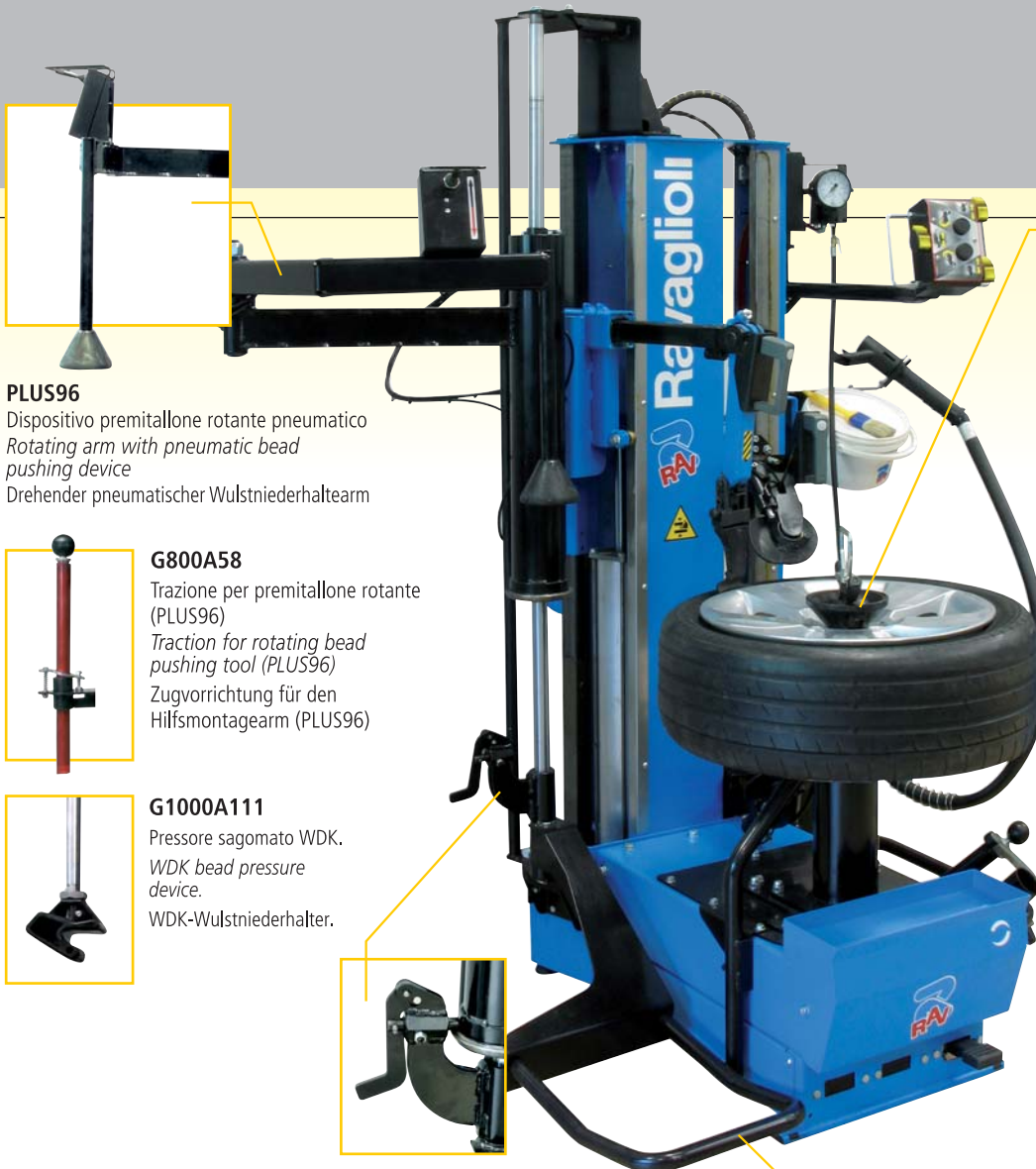

PLUS96
Dispositivo premitallone rotante pneumatico
Rotating arm with pneumatic bead pushing device
Drehender pneumatischer Wulstniederhalter

G800A58
Trazione per premitallone rotante (PLUS96)
Traction for rotating bead pushing tool (PLUS96)
Zugvorrichtung für den Hilfsmontagearm (PLUS96)

G1000A111
Pressore sagomato WDK.
WDK bead pressure device.
WDK-Wulstniederhalter.

G1000A72
Flangia universale per ruote senza foro centrale e adatta anche a ruote rovesce
Universal flange for closed centre, adapted also for reverse rims.
Universalfansch für Räder mit Blindbohrungen, geeignet auch für Reverse-Rim-Design.

G1000A112 (→ PLUS96)
Sollevatore pneumatico ruote.
Pneumatic wheel lifter.
Pneumatischer Radheber.



G1000A80
Bloccaggio rapido
Quick-fit locking
Schnellspannung



G1000A66K (5 x kit)
Protezione cono di bloccaggio
Set of protections of locking cone
Satz Schutz Zugvorrichtung



G1000A70K (5 x kit)
Protezione trascinatore
Set of protections for pulling unit
Satz Schutz Zugvorrichtung



G1000A81K (10 x kit)
Protezione ruote rovesce in gomma
Set of rubber protections for support plate
Satz Scheiben-Schutz (Gummi)

DATI TECNICI	TECHNICAL DATA	TECHNISCHE DATEN	
Lavora su ruote da	<i>Handled wheels from</i>	Geeignet für Räder	10"-26" / 12"-28" / 14"-30"
Peso	<i>Weight</i>	Gewicht	300 kg (318 kg IT)
Larghezza max ruota	<i>Max wheel width</i>	Radbreite, max.	15"
Diam. max ruota	<i>Max wheel diam.</i>	Raddiameter, max	45"
Forza di stallon.(ogni rullo)	<i>Bead break.pow. (each arm)</i>	Abdrückkraft (jeder Arm)	1200 kg
Coppia max	<i>Max torque</i>	Drehmoment, max	120 Kgm
Movimento di stallonam.	<i>Bead breaker movement</i>	Abdrückbewegung	automatic
Motore di rotazione	<i>Rotation Motor</i>	Motor Drehung	1,5 Kw inverter motor +0,75 Kw motor
Pressione raccomandata	<i>Recommended air supply</i>	Empfohlener Druck	8 -10 bar
Voltaggio	<i>Power Supply</i>	Voltage	1ph, 200/265v, 50/60Hz

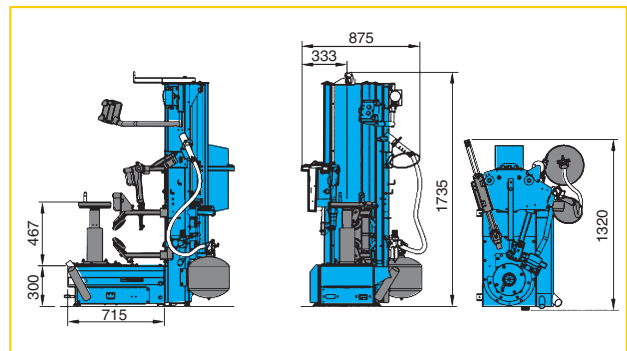

Ravaglioli S.p.A.
via 1° maggio 3
Fraz. Pontecchio M.
40037 Sasso Marconi (Bo) - Italia
Tel. +39 - 051 - 6781511
Fax +39 - 051 - 846349
rav@ravaglioli.com
www.ravaglioli.com

RAV France
6, Rue Longue Raie
ZAC de la Tremblaie
91220 Le Plessis Pâté
Tel. 01.60.86.88.16
Fax 01.60.86.82.04
rav@ravfrance.fr

Ravaglioli Deutschland
Kirchenpoint 22
85354 Freising
Tel. 08165-646956
Fax 08165-646958
info@ravaglioli.de

RAV Equipment UK LTD
Prince Albert House
20 King Street
Maidenhead, SL6 1DT
Tel. 020-76286832
Fax 020-76286833
ravuk@ravaglioli.com

RAV en Belgique
Nederlandstalig
Tel. 0498-162016
Fax 016-781025
Zone Francophone
Tel. 0498-163016
Fax 078 055 030

RAV Equipos España
Avenida Europa 17
Pol. Ind. de Constanti
Tarragona 43120
Tel. 977 524525
Fax 977 524532
ravequipos@ravaglioli.e.telefonica.net

DRN20D (1)

Le caratteristiche tecniche e gli allestimenti presentati in questo prospetto possono subire variazioni. Le immagini riprodotte non sono vincolanti.
Technical data and composition presented in this catalogue may vary. Pictures reproduced are only indicative.
Die techn. Daten und die Ausrüstungen, die in diesem Prospekt enthalten sind, können Änderungen erfahren. Deshalb sind die Abbildungen unverbindlich.

